



## Card/Wristband Collector Pillar

DSSP6001A

Card Collector



DSSP6001B

Wristband Collector



### Features

- The card and wristband collector device is an access control machine to swallow card as a stand-alone unit.
- The system always integrates with turnstiles or other gates to use together. When the machine collects the card, the connective gates will open automatically.
- The body is made of brushed stainless steel which is robust, rigid, anti-rust and durable.
- It is suitable for indoor applications.
- It's with LED indicator (red × means no entry; green → means entry).
- Easy installation and maintain.
- 3 years free warranty.

## Dimensions

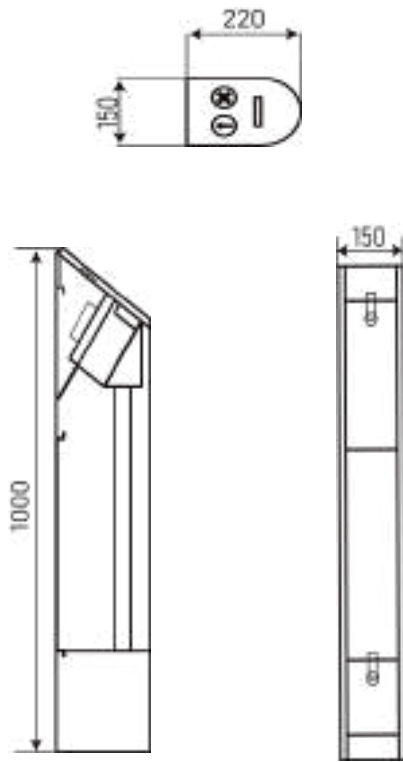

DSSP6001A

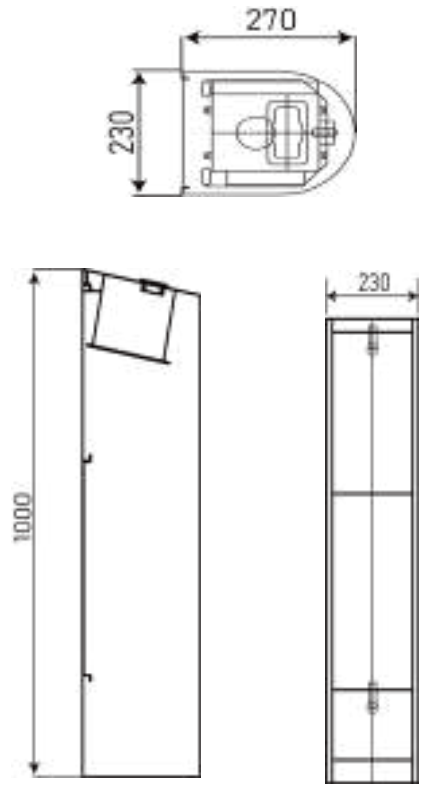

DSSP6001B

## Specifications

Model No.	DSSP6001
Brand	Daosafe
Framework Material	304 Full Stainless Steel + Black Rubber
Dimension	DSSP6001A: 220 * 150 * 1000(mm) DSSP6002B: 270 * 230 * 1000(mm)
Weight	DSSP6001A: 20kg/pcs DSSP6001B: 25kg/pcs
Power Supply	AC220V/110V, 50/60Hz
Operation Voltage	24V DC
Power Consumption	20W
Operation Temperature	-15 °C - 60 °C
Operation Humidity	0 ~ 95% (No freeze)
LED Indicator	Yes
Optional Model	DSSP6001A, DSSP6002B